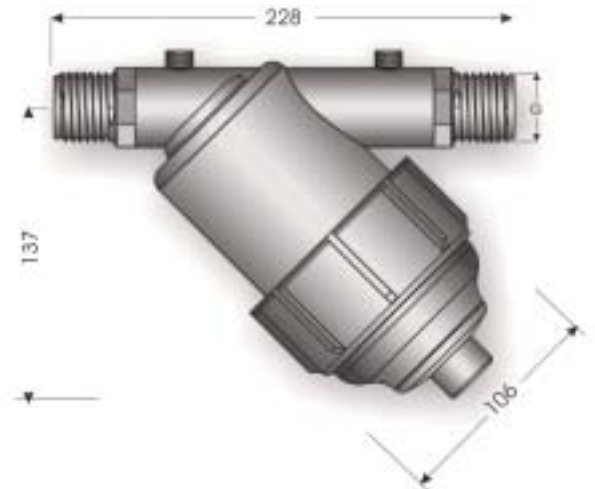

3/4", 1", 1"1/4
Q max. = 4,8 - 10,2 m³/h

Kód	Rozmer	Typ
2015.01 C1S	3/4"	Bez vypúšťania
2015.02 C1T	3/4"	So zátkou
2015.03 C1V	3/4"	S ventilom
2015.07 D1S	1"	Bez vypúšťania
2015.08 D1T	1"	So zátkou
2015.09 D1V	1"	S ventilom
2015.13 E1S	1"1/4	Bez vypúšťania
2015.14 E1T	1"1/4	So zátkou
2015.15 E1V	1"1/4	S ventilom
2015.19 C-N	Cartuša Nylon	

Rozmer	3/4"	1"	1"1/4
Max pracovný tlak:	8 bar	8 bar	8 bar
Max doporučený prietok:	80 l/min (4,8 m ³ /h)	130 l/min (7,8 m ³ /h)	170 l/min (10,2 m ³ /h)
Filtračná plocha:	120 cm ²	120 cm ²	120 cm ²

3/4", 1", 1"1/4 Predĺžené
Q max. = 4,8 - 10,2 m³/h

Kód	Rozmer	Typ
2015.04 C2S	3/4"	Bez vypúšťania
2015.05 C2T	3/4"	So zátkou
2015.06 C2V	3/4"	S ventilom
2015.10 D2S	1"	Bez vypúšťania
2015.11 D2T	1"	So zátkou
2015.12 D2V	1"	S ventilom
2015.16 E2S	1"1/4	Bez vypúšťania
2015.17 E2T	1"1/4	So zátkou
2015.18 E2V	1"1/4	S ventilom
2015.20 A	Cartuša nylon predĺžená	

Rozmer	3/4"	1"	1"1/4
Max pracovný tlak:	8 bar	8 bar	8 bar
Max doporučený prietok:	90 l/min (5,4 m ³ /h)	150 l/min (9,0 m ³ /h)	180 l/min (10,8 m ³ /h)
Filtračná plocha:	170 cm ²	170 cm ²	170 cm ²

Výmenné sieťové kartuše

Mesh	Otvor mm	Priemer vlákna mm	A %
80	195	100	43
100	175	90	42
120	135	70	42
150	100	61	38

Materiál: polyamid

A = Pomer medzi plochou otvorov a celkovou plochou sieťoviny

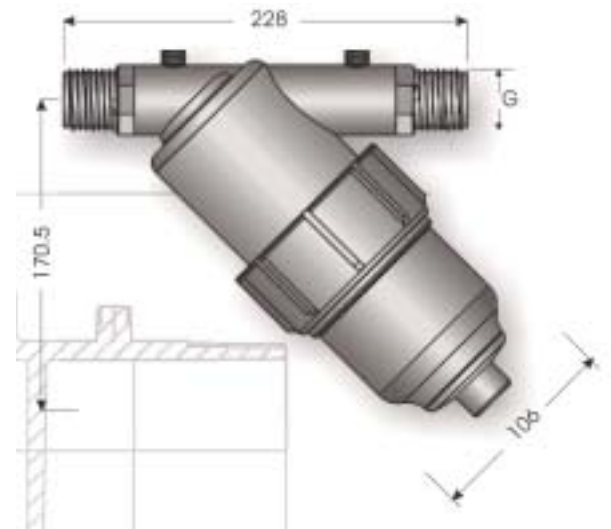
1"1/4, 1"1/2
Q max. = 15,6 - 18 m³/h

Kód	Rozmer	Typ
20020-E1S	1"1/4	Bez vypúšťania
20020-E1T	1"1/4	So zátkou
20020-E1V	1"1/4	S ventilom
20020-F2S	1"1/2	Bez vypúšťania
20020-F2T	1"1/2	So zátkou
20020-F2V	1"1/2	S ventilom
C20020	Cartuša Nylon	

Rozmer	1"1/4	1"1/2
Max pracovný tlak:	8 bar	8 bar
Max doporučený prietok:	260 l/min (15,6 m ³ /h)	300 l/min (18,0 m ³ /h)
Filtračná plocha:	215 cm ²	215 cm ²

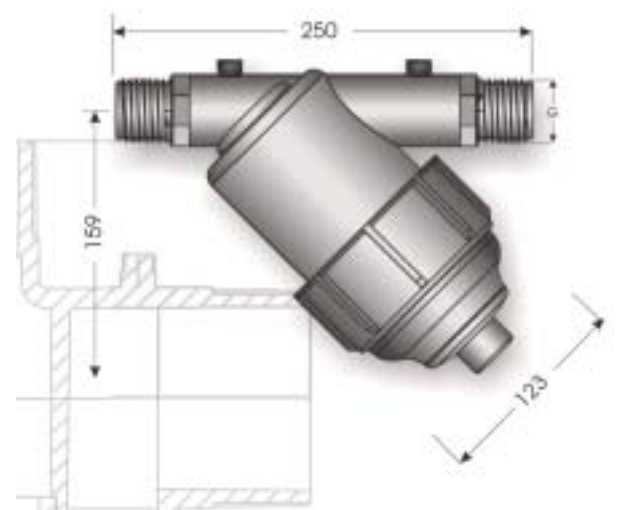

1"1/2, 2"

Q max. = 27,6 - 30,0 m³/h

Kód	Rozmer	Typ
20025-F1S	1"1/2	Bez vypúšťania
20025-F1T	1"1/2	So zátkou
20025-F1V	1"1/2	S ventilom
20025-G2S	2"	Bez vypúšťania
20025-G2T	2"	So zátkou
20025-G2V	2"	S ventilom
C20025	Cartuša Nylon 1"1/2 - 2"	



Rozmer	1"1/2	2"
Max pracovný tlak:	8 bar	8 bar
Max doporučený prietok:	400 l/min (24 m ³ /h)	430 l/min (25,8 m ³ /h)
Filtračná plocha:	340 cm ²	340 cm ²

2", 3"

Q opt. = 28,8 - 48 m³/h

Kód	Rozmer	Typ
20920-G1T	2"	So zátkou
20920-G1V	2"	S ventilom
20920-L2T	3"	So zátkou
20920-L2V	3"	S ventilom
C20920	Cartuša PP 2" - 3"	
	Cartuša Inox 2" - 3"	

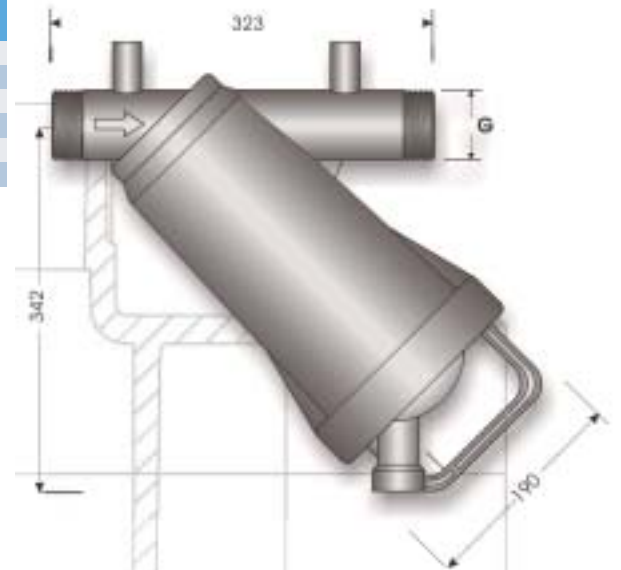

Rozmer	2"	3"
Max pracovný tlak:	8 bar	8 bar
Max doporučený prietok:	480 l/min (28,8 m ³ /h)	800 l/min (48 m ³ /h)
Filtračná plocha:	170 cm ²	170 cm ²